

# Artesian Owners Manual

## Energy-Efficient, Self Priming Centrifugal Pumps

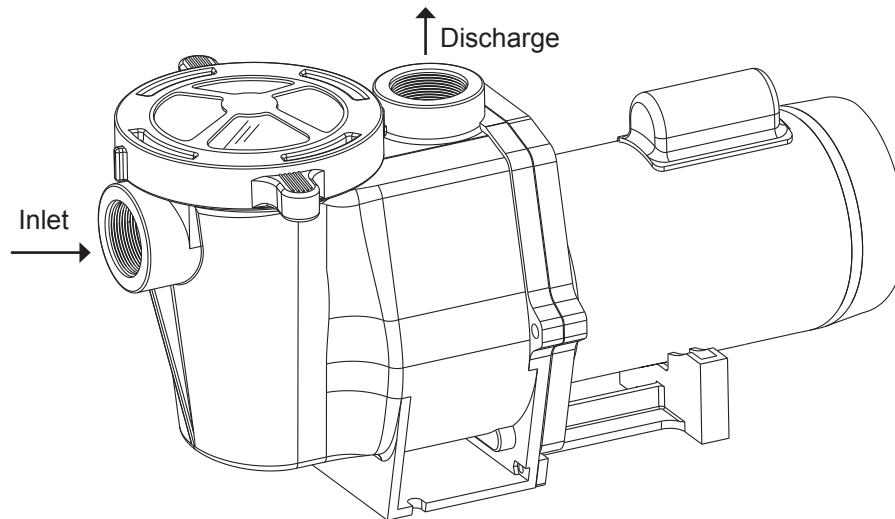

### Important Safety Instructions

Please read all instructions completely before you install or operate your new pump.  
Save this manual for future reference.

### General Specifications

Housing - Corrosion resistant polypropylene.

Port size - 2" female NPT on both inlet and discharge.

Seal - Stationary type - Stainless Steel, with Buna trim, for 5/8" shaft.

Motors - NEMA 56Y Frame: Available in 1/8 to 1/2hp at 1725 RPM and 1/2 to 3hp at 3450 RPM.

We use a variety of motor manufactures including A.O. Smith, Baldor, Emerson, Leeson, Reliance, and U.S. Motors.

## WARNINGS

1. This pump and motor unit should be installed by a qualified electrician or serviceman in accordance with all applicable state and local codes and ordinances, and in accordance with the National Electrical Code. Improper installation may create a mechanical or electrical hazard which could cause damage to property and which could result in serious injury or death.
2. In order to avoid serious injury or death, always disconnect power to the motor before servicing the pump.
3. Never run the pump dry. You must fill the priming pot (volute) with water before starting the motor.
4. Never start the pump when the motor shaft is turning. To prevent unwanted motor rotation, install a swing type check valve.
5. If you aren't competent to instal the pump, get help from a qualified source.
6. Have a minimum flow rate of two gallons per minute.



5976 SE Alexander Street, Suite F, Hillsboro, OR 97123  
P: 503-356-5888 F:503-356-1660  
[www.performancepropumps.com](http://www.performancepropumps.com)

# Installation

## General

Proper installation of your Artesian pump will help insure years of trouble free service.

1. Position the pump as near to the water and as low as is practical. This will help reduce priming time, avoid cavitation, and maximize your pumps performance.
2. Minimize friction losses by using large diameter pipe, reducing the length of runs, and minimizing the number of elbows and fittings as much as possible.
3. Protect the motor from excessive heat. It is best to provide shade from direct sun, and insure that it has proper ventilation. Excessive heat will shorten the motors life and void the warranty.
4. Protect the motor against dirt, water and all foreign matter. If the motor has been flooded, do not operate it until it has been checked by an authorized motor technician, and has been found to be safe to operate. If the motor is damaged by dirt, moisture, or corrosion it voids the warranty.
5. Mount the motor to a stable base where it won't get submerged.
6. The pump ports are 2" NPT female on both the inlet and discharge ports. The fittings used to connect to the housing should be plastic. All plumbing lines should be self supported and properly aligned. This will prevent undue stress to the housing. We recommend sealing the pipe to pump connections with TFE (Teflon) paste (Not Teflon tape).
7. Installations in which the discharge pipe is elevated above the pump must use a swing type check valve to prevent reverse rotation.
8. BEFORE STARTING THE PUMP, YOU MUST FILL THE PRIMING POT WITH WATER.
9. Refer to our Installation Hints page for more information.

---

## Electrical

1. If you are not competent to wire an electric motor, hire someone who is!
2. Make sure the power is disconnected before wiring the motor.
3. Make sure that the motor is wired internally so that it matches the supply voltage. If they do not match it will damage your motor and void the warranty. i.e. if you are connecting it to a 115V breaker, make sure the motor connections match the 115V (low) wiring diagram found on your particular motor.
4. Use a supply wire of adequate gauge to prevent electrical line losses. The use of heavier gauge wire will allow the motor to run cooler and more efficiently, by eliminating excessive line voltage loss.
5. Make sure all connections are clean and tight. Properly ground the motor. (There is normally a green ground terminal located inside the motor connection box.) Make sure the ground wire is properly connected to an electrical service ground.
6. Connect the pump permanently to an adequately sized circuit. It is best to have a dedicated circuit that won't suffer a voltage drop from other loads.

---

## Pump Disassembly

All moving parts are located in the rear sub-assembly of this pump. Tools required:

1. 3/32 inch Allen wrench.
2. 7/16 inch open end wrench.
3. 9/16 inch open end wrench.
4. Small and large flat bladed screwdrivers.
5. Large Phillips screw driver.

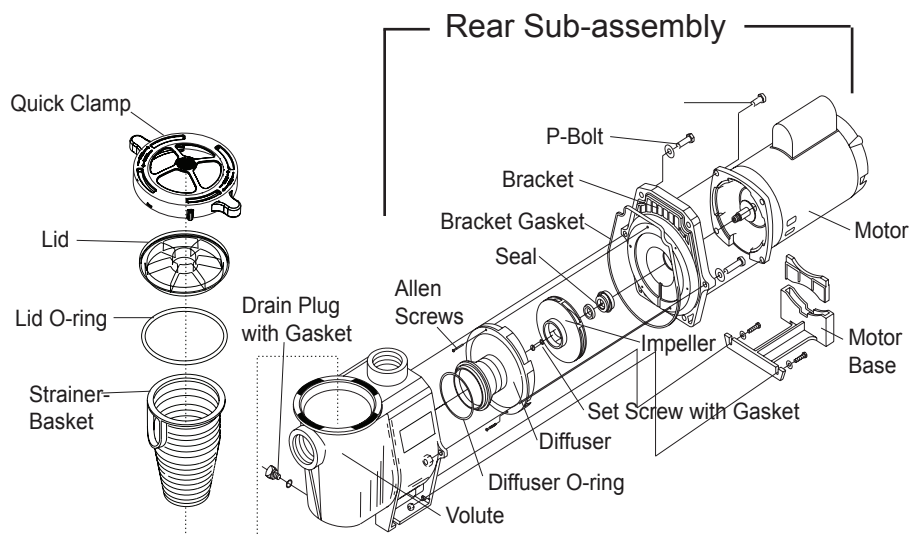

## Pump Disassembly Continued

Disassembly and repair of the motor sub-assembly can be made as follows:

1. At the main panel turn off the circuit breaker for the pump.
2. Close all necessary valves on inlet and discharge lines and drain the pump by removing both drain plugs.
3. Loosen and remove the six 3/8" P-bolts that hold the volute and the bracket together.
4. Pull the rear sub-assembly away from the volute. (The volute can remain attached to the plumbing.)
5. Loosen and remove the two 3/32" Allen screws that hold the diffuser to the bracket and remove the diffuser.
6. Remove the set screw (if it has one) from the impeller eye. To do this, hold the impeller stationary, and turn the set screw clockwise (it has a left-handed thread).
7. Hold the motor shaft stationary (by removing the cap on the opposite end of the motor and inserting a screw driver in the slot, or a wrench on the flats, depending on the motor design) and unscrew the impeller by turning it counter clockwise.
8. Loosen and remove the four 3/8" M-bolts that hold the bracket to the motor face.
9. If you wish to remove the shaft seal, place the bracket face down on a flat surface and press out the carbon/spring seal from the back side. Never pry it out from the front.
10. Carefully remove the ceramic from the back impeller hub with a small straight screw driver.
11. Clean the bracket, seal bore housing, and the motor shaft as necessary.

---

## Pump Assembly

1. To install a new shaft seal, clean or replace the o-ring in the bore. If there is no o-ring, clean the bore and apply a bead of 100% silicon sealant inside the bore and around the top edge.
2. Press the seal into the bore (without touching or putting pressure on the delicate carbon face) by pushing on the stainless steel collar. (A large socket or a pipe nipple can be used). Make sure it is uniformly seated all the way around.
3. Clean as necessary the impeller hub, and press in the ceramic. Make sure that it is sitting flat. (The white ceramic face must be showing - Not the rubber boot!)
4. Remount the bracket to the motor. Tighten the four M-Bolts (3/8" cap screws).
5. Screw the impeller clockwise onto the motor shaft (while holding the motor shaft stationary) until it makes firm contact. Screw in the impeller set screw (if it has one), with its gasket in place, (counter-clockwise to tighten).
6. Mount the diffuser onto the bracket. Make sure the plastic pins fit into the holes in the bracket, then tighten both Allen head screws.
7. Make sure the diffuser O-ring and bracket gasket are clean and properly seated.
8. Assemble the motor sub-assembly to the volute by using the two P-Bolts (3/8" cap screws) through bolts with nuts for proper alignment. Do not tighten the through bolts until all six P-bolts are in place and finger tightened. Tighten all six bolts uniformly and in a cross pattern.
9. Insert both drain plugs with gaskets and tighten. Install strainer basket and fill the pump with water.
10. Reinstall the lid and quick clamp, and turn it clockwise until snug.

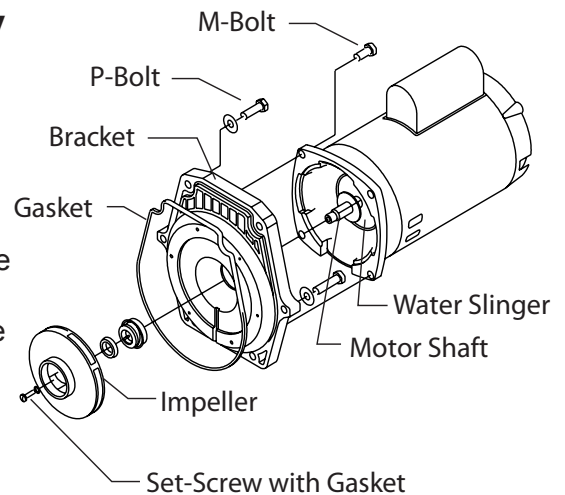

## Caution

1. The polished and lapped faces of the seal could be damaged if not handled with care.
2. DO NOT RUN THE PUMP DRY. It must be filled with water before it is turned on.

# **PerformancePro Pumps Artesian Series Limited Warranty**

PerformancePro Pumps warrants its single and two speed Artesian series of centrifugal pumps to be free of defects in material and/or workmanship at the time of purchase. In the event this product malfunctions within three years from the date of purchase, the sole obligation of PerformancePro Pumps will be to repair or replace the product. The three year period applies only to pump and motor units used for fresh water applications. A one year period applies to pumps used in brackish, saltwater or other suitable applications.

THIS LIMITED WARRANTY IS SUBJECT TO THE FOLLOWING CONDITIONS AND EXCLUSIONS:

1. PerformancePro Pumps must perform all warranty repairs. Purchaser must retain the purchase receipt and present it with this certificate as proof of ownership and entitlement to warranty repairs. Unauthorized repairs will not be compensated by PerformancePro Pumps, and are not the responsibility of PerformancePro Pumps. If such repairs damage the product, such damage is not remediable under this warranty.
2. Problems or damage resulting from failure to comply with instructions in the owner's manual, improper plumbing and positioning, flooding, corrosion or salt build up, incompatibility with fluid chemistry and running unit dry are not covered under this warranty. Malfunction for any other reason - including but not limited to misuse, negligence, accident, tampering with parts, incorrect wiring, or improper installation - will not be remedied under this warranty.
3. Purchaser shall bear all shipping, packing, and insurance costs and all other costs, excluding labor and parts necessary to effectuate repairs under this warranty.
4. Periodic check-ups are not covered by this warranty.
5. This is the sole and exclusive manufacturer's warranty. Any and all implied warranties, including any warranties of merchantability and fitness for particular purpose, shall have no greater duration than the duration period of the express written warranty applicable to this product, and shall terminate automatically upon the expiration of such duration period. Some states do not allow limitations on how long an implied warranty lasts, so the above limitation may not apply to you. No action shall be brought for breach of any express warranty subsequent to the expiration of this express written warranty. Except as is otherwise provided by applicable law, no action on a warranty implied at law shall be commenced more than one year following the date of purchase.
6. Incidental and consequential damages (specifically including, but not limited to, damages for loss of profits or damages relating to down time of people or equipment) caused by malfunction, defect, or otherwise, and with respect to breach of any express or implied warranty, are not the responsibility of PerformancePro Pumps, and, to the extent permitted by law, are hereby excluded both for property damage and, to the extent not prohibited by applicable law, for personal injury damage. Some states do not allow the exclusion or limitation of incidental or consequential damages, so the above limitation or exclusion may not apply to you.
7. The provisions of this warranty are severable and if any provision shall be deemed invalid, the remaining provisions shall remain in full force and effect.
8. Rights under this warranty are not assignable without the express prior consent in writing by PerformancePro Pumps. Regardless of the terms of any consent in writing, the assignees shall have no greater rights than his assignor had against PerformancePro Pumps. Any purported assignment without the consent of PerformancePro Pumps shall be null and void.
9. This contract shall be governed by and in accordance with the laws of the state of Oregon.
10. This limited warranty is incorporated by reference into the contract of purchase for the products supplied by PerformancePro Pumps to purchaser under said contract.

**ARTESIAN PUMP PLACEMENT CHART**



When determining the placement of your Artesian pump, two factors will be influenced by its height above water level. First, is its ability to self-prime. To insure a reasonable prime time without the use of a swing type check valve (do not use spring loaded check valves), position the pump no higher than the height shown in the "maximum recommended suction lift" column. Second, is its ability to maintain a prime and minimize cavitation. Even with a swing type check valve, we do not recommend a pump be installed more than 9 feet above the water level.

MODEL	MAXIMUM RECOMMENDED SUCTION LIFT	APPROXIMATE TIME TO PRIME
A 1/8-30	1 FOOT	15 MINUTES
A 1/8-35	3 FEET	15 MINUTES
A 1/4-40	4 FEET	15 MINUTES
A 1/4-49	3 FEET	15 MINUTES
A 1/3-56	4 FEET	10 MINUTES
A 1/2-75	4 FEET	10 MINUTES
A 1/2	8 FEET	5 MINUTES
A 3/4	8 FEET	5 MINUTES
A 1	8 FEET	5 MINUTES
A 1 1/2	8 FEET	5 MINUTES
A 2	8 FEET	5 MINUTES
A 3	8 FEET	5 MINUTES

**Notes:**

1. The data in this chart was compiled using 2" pipe, 10' in length. If you use larger pipe or have longer runs, it will increase the time required to prime.
2. All PerformancePro self-priming pumps have been tested to operate up to a height of 9' above the surface of the water. Do not install your pump higher than 9'.
3. If you use small pipe, more fittings, have longer runs, use strainers, or in any other way make it harder for water to flow easily to the pump - it will reduce your maximum recommended height and may increase the time to prime.

**PerformancePro Pumps Inc.**

5976 S.E. Alexander St., Suite F, Hillsboro, OR 97123  
Phone: 503/356-5888 Fax: 503/356-1660  
www.performancepropumps.com



For performance that's OFF THE CHART of ordinary pumps!

## WIRING INSTRUCTIONS



### IMPORTANT SAFETY INSTRUCTIONS

**Please read all instructions completely before you install or operate your new pump. Save these instructions for future reference.**



The motors used with the PerformancePro pumps are high quality, industrial duty motors. Some are dual voltage motors, which can be operated at either 115 volt (low) or 230 volt (high). They have been tested at the factory before being shipped.

It is vitally important to supply proper voltage and amperage to the motor. Set the internal connections on your motor to match your supply line voltage. If these do not match, you will damage the motor and void the warranty. DO NOT ATTEMPT TO WIRE THE MOTOR IF YOU DON'T KNOW WHAT YOU ARE DOING!!! Have a qualified electrician do the work.

The following example shows how to wire a typical Baldor 1/4HP, Single Phase, 1725 RPM motor (with the following diagram)

LOW VOLTAGE		
LINE A	LINE B	TOGETHER
1, 3	4	2, J

HIGH VOLTAGE			
LINE A	LINE B	TOGETHER	TAPE
1	4	2, 3	J

CONNECTIONS ABOVE GIVE CLOCKWISE ROTATION FACING LEAD END.

For low voltage:

1. Connect your incoming hot lead (normally the black wire) to the wires marked #1 and #3.
2. Connect your incoming neutral lead (normally the white wire) to the #4 wire.
3. Twist wires #2 and #J together.
4. Use appropriately sized wire nuts to insure all connections are secure and insulated.
5. Connect your incoming ground (normally green) to the green screw in the connection box.

For high voltage:

1. Connect your incoming hot lead (normally the black wire) to wire #1.
2. Connect your other hot lead (normally the white wire) to wire #4.
3. Connect wire #2 and #3 together.
4. Tape off the wire marked J.
5. Use appropriately sized wire nuts to insure all connections are secure and insulated.
6. Connect your ground lead (normally green) to the green screw in the connection box.

**Note: Your motor may have a different wiring diagram. Follow it's instructions for line placement.**

**PerformancePro Pumps Inc.**

5976 S.E. Alexander St., Suite F, Hillsboro, OR 97123  
Phone: 503/356-5888 Fax: 503/356-1660  
www.performancepropumps.com